

# **Airsoft Certification**

***Self Assessment Exam AEG01, Version 1,***

***ANSWERS***

***Proudly presented by the AirsoftPRESS***

# **Airsoft Certification AEG01 Self-assessment V1 ANSWERS**

## **End User License Agreement**

This e-Book (the "Book") is a product provided by the AirsoftPRESS (being referred to as "AirsoftPRESS" in this document), subject to your compliance with the terms and conditions set forth below.

PLEASE READ THIS DOCUMENT CAREFULLY BEFORE ACCESSING OR USING THE BOOK. BY ACCESSING OR USING THE BOOK, YOU AGREE TO BE BOUND BY THE TERMS AND CONDITIONS SET FORTH BELOW. IF YOU DO NOT WISH TO BE BOUND BY THESE TERMS AND CONDITIONS, YOU MAY NOT ACCESS OR USE THE BOOK. AIRSOFTPRESS MAY MODIFY THIS AGREEMENT AT ANY TIME, AND SUCH MODIFICATIONS SHALL BE EFFECTIVE IMMEDIATELY UPON POSTING OF THE MODIFIED AGREEMENT ON THE CORPORATE SITE OF AIRSOFTPRESS. YOU AGREE TO REVIEW THE AGREEMENT PERIODICALLY TO BE AWARE OF SUCH MODIFICATIONS AND YOUR CONTINUED ACCESS OR USE OF THE BOOK SHALL BE DEEMED YOUR CONCLUSIVE ACCEPTANCE OF THE MODIFIED AGREEMENT.

1. Copyright and Licenses.

### **License Grant**

This Agreement entitles you to install and use one copy of the Book. In addition, you may make one archival copy of the Book. The archival copy must be on a storage medium other than a hard drive, and may only be used for the reinstallation of the Book. This Agreement does not permit the installation or use of multiple copies of the Book, or the installation of the Book on more than one computer at any given time, on a system that allows shared use of applications, on a multi-user network, or on any configuration or system of computers that allows multiple users. Multiple copy use or installation is only allowed if you obtain an appropriate licensing agreement for each user and each copy of the Book. For further information regarding multiple-copy licensing of the Book, please contact: [editor@AirsoftPRESS.com](mailto:editor@AirsoftPRESS.com) .

### **Restrictions on Transfer**

Without first obtaining the express written consent of AirsoftPRESS, you may not assign your rights and obligations under this Agreement, or redistribute,

## **Airsoft Certification AEG01 Self-assessment V1 ANSWERS**

encumber, sell, rent, lease, sublicense, or otherwise transfer your rights to the Book.

### **Restrictions on Use**

You may not use, copy, or install the Book on any system with more than one computer, or permit the use, copying, or installation of the Book by more than one user or on more than one computer. If you hold multiple, validly licensed copies, you may not use, copy, or install the Book on any system with more than the number of computers permitted by license, or permit the use, copying, or installation by more users, or on more computers than the number permitted by license.

You may not decompile, "reverse-engineer", disassemble, or otherwise attempt to derive the source code for the Book.

### **Restrictions on Alteration**

You may not modify the Book or create any derivative work of the Book or its accompanying documentation. Derivative works include but are not limited to translations. You may not alter any files or libraries in any portion of the Book. You may not reproduce the database portion or create any tables or reports relating to the database portion.

### **Restrictions on Copying**

You may not copy any part of the Book except to the extent that licensed use inherently demands the creation of a temporary copy stored in computer memory and not permanently affixed on storage medium. You may make one archival copy which must be stored on a medium other than a computer hard drive.

## 2. Use of the Book.

You understand that, except for information, products or services clearly identified as being supplied by AirsoftPRESS, AirsoftPRESS does not operate, control or endorse any information, products or services on the Internet in any way. Except for AirsoftPRESS- explicitly identified

## **Airsoft Certification AEG01 Self-assessment V1 ANSWERS**

information, products or services, all information, products and services offered through the Book or on the Internet generally are offered by third parties that are not affiliated with AirsoftPRESS.

YOU ASSUME TOTAL RESPONSIBILITY AND RISK FOR YOUR USE OF THE BOOK AND THE INTERNET. AIRSOFTPRESS PROVIDES THE BOOK AND RELATED INFORMATION "AS IS" AND DOES NOT MAKE ANY EXPRESS OR IMPLIED WARRANTIES, REPRESENTATIONS OR ENDORSEMENTS WHATSOEVER (INCLUDING WITHOUT LIMITATION WARRANTIES OF TITLE OR NONINFRINGEMENT, OR THE IMPLIED WARRANTIES OF MERCHANTABILITY OR FITNESS FOR A PARTICULAR PURPOSE) WITH REGARD TO THE BOOK, ANY INFORMATION OR SERVICE PROVIDED THROUGH THE BOOK, AND AIRSOFTPRESS SHALL NOT BE LIABLE FOR ANY COST OR DAMAGE ARISING EITHER DIRECTLY OR INDIRECTLY FROM ANY SUCH. IT IS SOLELY YOUR RESPONSIBILITY TO EVALUATE THE ACCURACY, COMPLETENESS AND USEFULNESS OF ALL OPINIONS, ADVICE, AND OTHER INFORMATION PROVIDED THROUGH THE BOOK.

### **LIMITATION OF LIABILITY**

**AirsoftPRESS will not be held liable for any advice or suggestions given in this book. If the reader wants to follow a suggestion, it is at his or her own discretion. Suggestions are only offered to help.**

IN NO EVENT WILL AIRSOFTPRESS BE LIABLE FOR (I) ANY INCIDENTAL, CONSEQUENTIAL, OR INDIRECT DAMAGES (INCLUDING, BUT NOT LIMITED TO, DAMAGES FOR LOSS OF PROFITS, BUSINESS INTERRUPTION, LOSS OF PROGRAMS OR INFORMATION, AND THE LIKE) ARISING OUT OF THE USE OF OR INABILITY TO USE THE BOOK. EVEN IF AIRSOFTPRESS OR ITS AUTHORIZED REPRESENTATIVES HAVE BEEN ADVISED OF THE POSSIBILITY OF SUCH DAMAGES, OR (II) ANY CLAIM ATTRIBUTABLE TO ERRORS, OMISSIONS, OR OTHER INACCURACIES IN THE BOOK.

AirsoftPRESS makes no representations whatsoever about any other web site which are referenced in the book. When you access a non-AirsoftPRESS web site, please understand that it is independent from AirsoftPRESS, and that AirsoftPRESS has no control over the content on that web site. In addition, a link to a AirsoftPRESS web site does not mean that AirsoftPRESS endorses or accepts any responsibility for the content, or the use, of such web site.

3. Indemnification.

## **Airsoft Certification AEG01 Self-assessment V1 ANSWERS**

You agree to indemnify, defend and hold harmless AirsoftPRESS, its officers, directors, employees, agents, licensors, suppliers and any third party information providers to the Book from and against all losses, expenses, damages and costs, including reasonable attorneys' fees, resulting from any violation of this Agreement (including negligent or wrongful conduct) by you or any other person using the Book.

### 4. Third Party Rights.

The provisions of paragraphs 2 (Use of the Book), and 3 (Indemnification) are for the benefit of AirsoftPRESS and its officers, directors, employees, agents, licensors, suppliers, and any third party information providers to the Book. Each of these individuals or entities shall have the right to assert and enforce those provisions directly against you on its own behalf.

### 5. Termination.

This Agreement may be terminated by either party without notice at any time for any reason. The provisions of paragraphs 1 (Copyright, Licenses and Idea Submissions), 2 (Use of the Book), 3 (Indemnification), 4 (Third Party Rights) and 6 (Miscellaneous) shall survive any termination of this Agreement.

### 6. Miscellaneous.

This Agreement shall all be governed and construed in accordance with the laws of Hong Kong applicable to agreements made and to be performed in Hong Kong. You agree that any legal action or proceeding between AirsoftPRESS and you for any purpose concerning this Agreement or the parties' obligations hereunder shall be brought exclusively in a court of competent jurisdiction sitting in Hong Kong. Any cause of action or claim you may have with respect to the Book must be commenced within one (1) year after the claim or cause of action arises or such claim or cause of action is barred. AirsoftPRESS's failure to insist upon or enforce strict performance of any provision of this Agreement shall not be construed as a waiver of any provision or right. Neither the course of conduct between the parties nor trade practice shall act to modify any provision of this Agreement. AirsoftPRESS may assign its rights and duties under this Agreement to any party at any time without notice to you. **Any rights not expressly granted herein are reserved.**

# Airsoft Certification AEG01 Self-assessment V1 ANSWERS

## Preface

The airsoft certification effort was originally part of a training program tailored for a major airsoft manufacturer in Asia. We were at that time appointed as the training consultant for the frontline production/QC staff force. In order to validate the skills learned, we devised a series of exams, including paper and pencil exams as well as lab based exams, for the staff to take at the end of the training.

We found that examination is a good way to verify one's skills and knowledge in the field of airsoft technology implementation and maintenance. So we came up with the idea of this airsoft certification.

This module includes MC based questions for your self assessment. The answers are available separately. Actual examination will be lab based and will be made ready for enrollment soon.

At AirsoftPRESS, we produce technical information based on input from practicing engineers, technicians and field operators who have been with Airsoft since the era of S.S. 9000. Because we are part of the industry, we know what information is really needed. We do not mind to criticize thing that doesn't work, and we will not hesitate to give you hacks and workarounds to difficult problems.



# **Airsoft Certification AEG01 Self-assessment V1 ANSWERS**

## **ALERT**

When answering the questions please make sure you pick the options that are realistic, practical and do-able cost effectively. Technically right option doesn't have to be appropriate or field practical!

## Airsoft Certification AEG01 Self-assessment V1 ANSWERS

Question 1:

Most TM mechboxes use which of the following kinds of screws (choose all that apply):

- A. Torx screws – T10
- B. Torx screws – T5
- C. Torx screws – T15
- D. Torx screws – T8
- E. Torx screws – T6
- F. None of the choices.

## Airsoft Certification AEG01 Self-assessment V1 ANSWERS

Question 2:

You need to open up a TM mechbox but you do not have the necessary screw driver for the special kind of screws that are in use. What should you do (choose the single BEST answer):

- A. order the screw driver directly from TM
- B. order a replacement driver from CA
- C. use a flat head screw driver
- D. use a cutter to cut off the screw heads
- E. use a drill bit to drill into the screws
- F. None of the choices.

## Airsoft Certification AEG01 Self-assessment V1 ANSWERS

Question 3:

You are repairing a TM mechbox. Some of the stock screws for closing the shell are lost. What should you do?

- A. order the screws from TM
- B. order replacement screws from Systema
- C. use replacement screws that come with the stock TM gun package
- D. use regular Philips screws instead
- E. None of the choices.

## Airsoft Certification AEG01 Self-assessment V1 ANSWERS

Question 4:

Which of the following brands/makes of mechboxes use hex screws for closing the shell (choose all that apply):

- A. Deepfire
- B. TM
- C. Systema
- D. PDI
- E. KM
- F. None of the choices.

## Airsoft Certification AEG01 Self-assessment V1 ANSWERS

Question 5:

When handling the smaller mechbox screws and springs you may find which of the following tools useful (choose the single BEST answer):

- A. needle-nosed plier
- B. small hand drill
- C. a pair of sharp scissors
- D. wire cutter
- E. straight edge file
- F. pen shape soldering iron

## Airsoft Certification AEG01 Self-assessment V1 ANSWERS

Question 6:

You need to produce several small holes on the plastic mechbox parts. Which of the following can be used if an electric drill is not available?

- A. needle-nosed plier
- B. small hand drill
- C. a pair of sharp scissors
- D. wire cutter
- E. straight edge file
- F. pen shape soldering iron
- G. None of the choices.

## Airsoft Certification AEG01 Self-assessment V1 ANSWERS

Question 7:

When repairing a MP5 AEG you will find a hex driver useful for which of the following purposes (choose the single BEST answer):

- A. for replacing the sector gear
- B. for replacing the spur gear
- C. for fine tuning the motor position
- D. for fixing the switch unit
- E. for increasing spring compression
- F. None of the choices.

## Airsoft Certification AEG01 Self-assessment V1 ANSWERS

Question 8:

Refer to the exhibit below:

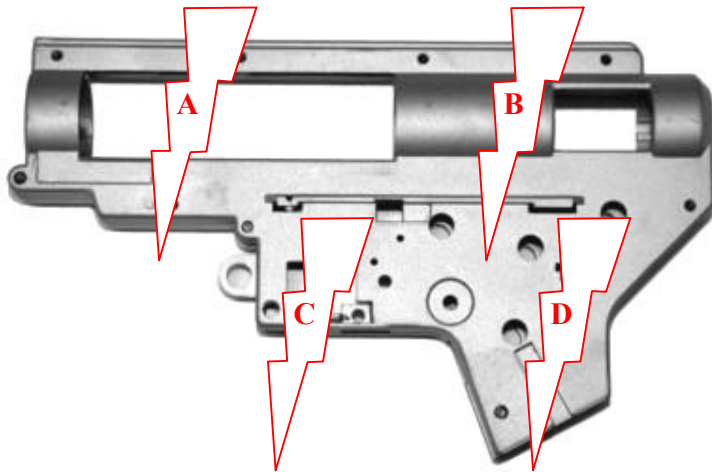

Which part(s) of the mechbox shown would most easily break with the use of a very strong spring?

- A. part A
- B. part B
- C. part C
- D. part D
- E. part A & C
- F. part B & D
- G. part C & B

## Airsoft Certification AEG01 Self-assessment V1 ANSWERS

Question 9:

Refer to the exhibit below:

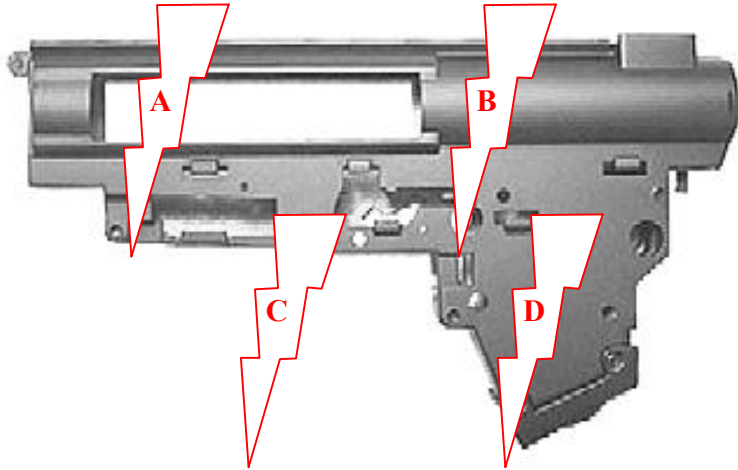

Which part(s) of the mechbox shown would most easily break with the use of a M140 spring from Systema?

- A. part A
- B. part B
- C. part C
- D. part D
- E. part A & C
- F. part B & D
- G. part C & B

## Airsoft Certification AEG01 Self-assessment V1 ANSWERS

Question 10:

Refer to the exhibit below:

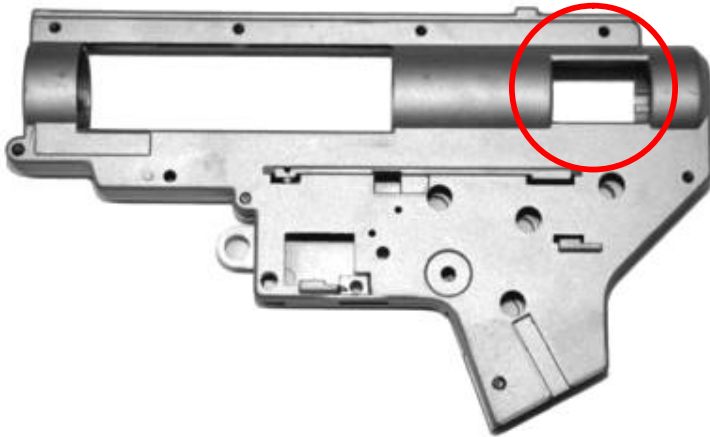

Why is the opening identified a MUST HAVE?

- A. You rely on it to achieve proper air volume balance.
- B. You rely on it for total noise suppression.
- C. You rely on it for the best possible spring compression.
- D. You rely on it for the best possible shell reliability.
- E. [None of the choices.](#)

## Airsoft Certification AEG01 Self-assessment V1 ANSWERS

Question 11:

Refer to the exhibit below:

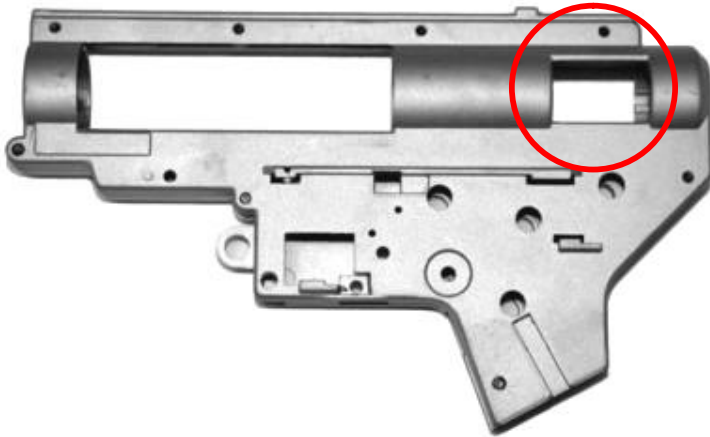

What can be achieved through the opening identified?

- A. Less friction for the cylinder
- B. Less friction for the piston
- C. Less friction for the piston O ring
- D. Less friction for the nozzle
- E. None of the choices.

## Airsoft Certification AEG01 Self-assessment V1 ANSWERS

Question 12:

Refer to the exhibit below:



Which of these gears is directly in contact with the motor pinion?

- A. the left most one
- B. the middle one
- C. the right most one
- D. None of the choices.

## Airsoft Certification AEG01 Self-assessment V1 ANSWERS

Question 13:

Refer to the exhibit below:



A gear delayer may be installed onto which of these gears?

- A. the left most one
- B. the middle one
- C. the right most one
- D. None of the choices.

## Airsoft Certification AEG01 Self-assessment V1 ANSWERS

Question 14:

Refer to the exhibit below:



To support all these gears how many ball bearings/metal bushings would you need?

- A. 6
- B. 4
- C. 2
- D. 8
- E. 10
- F. None of the choices.

## Airsoft Certification AEG01 Self-assessment V1 ANSWERS

Question 15:

Refer to the exhibit below:



For an ultra ROF setup the technique of teeth removal may be practiced on which of these gears (choose all that apply):

- A. the left most one
- B. the middle one
- C. the right most one
- D. None of the choices.

## Airsoft Certification AEG01 Self-assessment V1 ANSWERS

Question 16:

Refer to the exhibit below:



The "one O clock" timing issue is related to which of these gears?

- A. the left most one
- B. the middle one
- C. the right most one
- D. the motor pinion

## Airsoft Certification AEG01 Self-assessment V1 ANSWERS

Question 17:

Too much room in the bushing space holders of the shell is bad due to which of the following reasons?

- A. It may allow the bushings to spin.
- B. It may lead to air leakage.
- C. It may lead to grease leakage.
- D. It may break the switch unit.
- E. None of the choices.

## Airsoft Certification AEG01 Self-assessment V1 ANSWERS

Question 18:

Refer to the exhibit below:

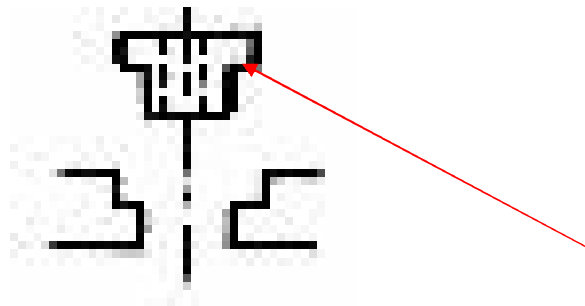

The part identified has been severely broken. What should you do?

- A. use lock tite on the bushing
- B. use lock tite on the bushing space holder
- C. [replace the bushing](#)
- D. replace the mechbox shell
- E. None of the choices.

## Airsoft Certification AEG01 Self-assessment V1 ANSWERS

Question 19:

Refer to the exhibit below:

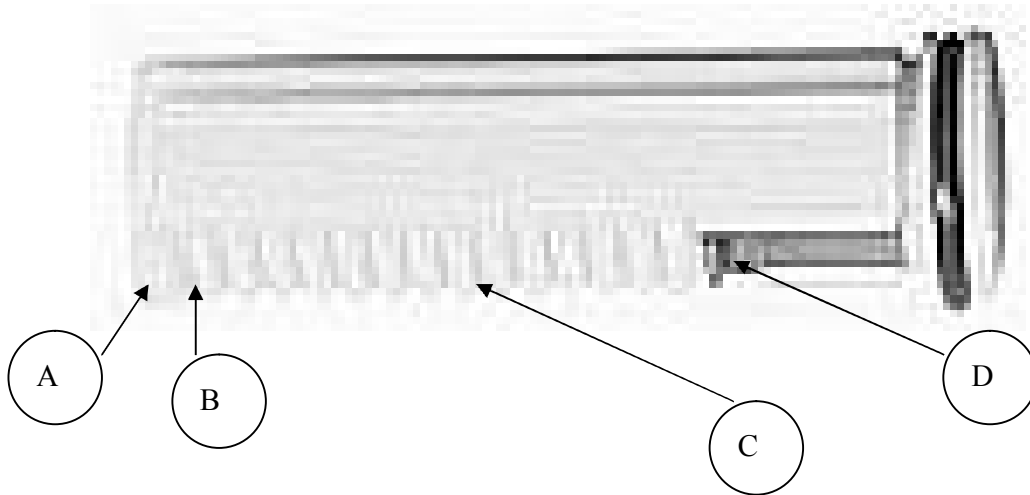

For an ultra high ROF setup the technique of teeth removal may be practiced on which part of the piston (choose all that apply):

- A. part A
- B. part B
- C. part C
- D. part D

## Airsoft Certification AEG01 Self-assessment V1 ANSWERS

Question 20:

Inside a V2 mechbox you typically have electrical contacts (choose all that apply):

- A. around the trigger unit.
- B. on the selector plate.
- C. inside the piston head.
- D. inside the nozzle.
- E. None of the choices.

## Airsoft Certification AEG01 Self-assessment V1 ANSWERS

Question 21:

Refer to the exhibit below:

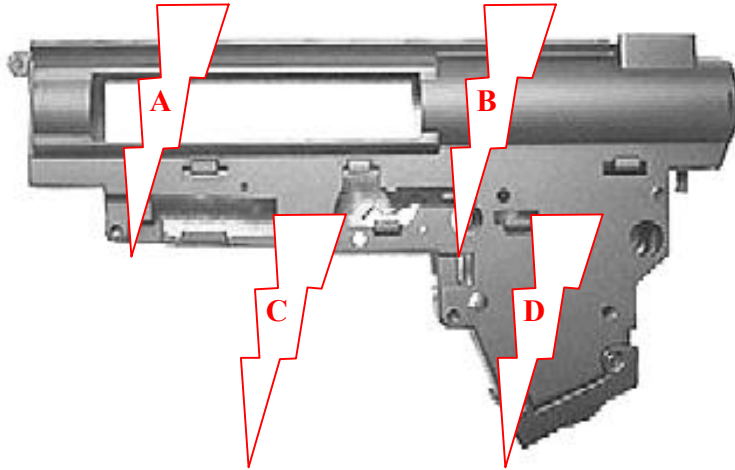

Which part(s) of the mechbox shown would require reinforcement in order to work perfectly for a TM Thompson?

- A. part A
- B. part B
- C. part C
- D. part D
- E. part A & C
- F. part B & D
- G. part C & B
- H. None of the choices.

## Airsoft Certification AEG01 Self-assessment V1 ANSWERS

Question 22:

What sort of modification would be necessary such that you can fit a FAMAS EG560 motor into a M4?

- A. you need to cut off some part of the M4 shell
- B. you need to use a MP5 pistol grip on the M4
- C. you need to replace the motor shell and nothing else
- D. you need to replace the motor shell, the brushes and nothing else
- E. you need to replace the motor shell, the pinion and nothing else
- F. [None of the choices.](#)

## Airsoft Certification AEG01 Self-assessment V1 ANSWERS

Question 23:

To reshim, why should you start by removing everything on the mechbox shell except for the bushings (choose the single BEST answer):

- A. By removing everything on the mechbox shell you can focus solely on the insertion and shimming of the 3 gears.
- B. By removing everything on the mechbox shell you can reinforce the shell.
- C. By removing everything on the mechbox shell you can glue the bushings properly.
- D. By removing everything on the mechbox shell you can lube the bushings properly.
- E. None of the choices.

## Airsoft Certification AEG01 Self-assessment V1 ANSWERS

Question 24:

What is the drawback of using plastic bushings (choose all that apply):

- A. They won't last long under 8.4V power.
- B. You cannot use silicon oil spray with them.
- C. They may burn easily
- D. They may break easily when using a stiff spring.
- E. They may break easily when using a PDI 100 spring.
- F. None of the choices.

## **Airsoft Certification AEG01 Self-assessment V1 ANSWERS**

Question 25:

Which of the following correctly describe the best possible way of reinforcing a V2 mechbox shell yourself?

- A. Don't bother – go buy an off the shelf product instead.
- B. Add two pieces of metal to the side of the shell.
- C. Apply an extra layer of plastic cement on the inner side of the shell.
- D. Apply an extra layer of plastic cement on the outer side of the shell.

## Airsoft Certification AEG01 Self-assessment V1 ANSWERS

Question 26:

What is the possible benefit of replacing the stock O ring with one that is slightly larger (choose all that apply):

- A. better air seal
- B. smoother piston movement
- C. less wear on the inner side of the cylinder
- D. better battery power utilization
- E. None of the choices.

## Airsoft Certification AEG01 Self-assessment V1 ANSWERS

Question 27:

What is the possible drawback of replacing the stock O ring with one that is quite a bit larger (choose all that apply):

- A. poor FPS
- B. poor ROF
- C. heavy workload for the motor
- D. heavy workload for the battery
- E. there is no drawback
- F. None of the choices.

## Airsoft Certification AEG01 Self-assessment V1 ANSWERS

Question 28:

Refer to the exhibit below:



Which of these gears interfaces directly with the anti reversal unit?

- A. the left most one
- B. the middle one
- C. the right most one
- D. the motor pinion
- E. None of the choices.

## Airsoft Certification AEG01 Self-assessment V1 ANSWERS

Question 29:

Refer to the exhibit below:



With improper shimming which of these gears can directly break the tappet plate?

- A. the left most one
- B. the middle one
- C. the right most one
- D. the motor pinion
- E. None of the choices.

## Airsoft Certification AEG01 Self-assessment V1 ANSWERS

Question 30:

After reshimming the gearbox you have difficulties putting the two halves back together. What is the likely cause?

- A. you have put too many shims somewhere.
- B. the wrong screws have been used.
- C. you forgot to lock the anti-reversal.
- D. your spring has not been grounded.
- E. None of the choices.

## Airsoft Certification AEG01 Self-assessment V1 ANSWERS

Question 31:

Which of the following manufacturers produce MP5 AEGs (choose all that apply):

- A. TM
- B. CA
- C. ICS
- D. Academy
- E. Dongsan
- F. Toystar
- G. Maruzen
- H. None of the choices.

## Airsoft Certification AEG01 Self-assessment V1 ANSWERS

Question 32:

Which of the following is the earliest AEG model produced by TM?

- A. MP5
- B. M4
- C. FAMAS
- D. L85
- E. G3
- F. None of the choices.

## Airsoft Certification AEG01 Self-assessment V1 ANSWERS

Question 33:

Which of the following AEG models rely on the EG560/compatible motor to power the mechbox (choose all that apply):

- A. MP5 ICS version
- B. M4
- C. FAMAS
- D. L85 Academy version
- E. L85 G&G version
- F. G3
- G. None of the choices.

## Airsoft Certification AEG01 Self-assessment V1 ANSWERS

Question 34:

After O ring replacement you go ahead and test fit the piston with the cylinder. When you move the piston inside the cylinder you feel no resistance at all. Which of the following is true (choose all that apply):

- A. the replacement O ring may be too small for your cylinder.
- B. the cylinder may wear too fast.
- C. the default cylinder opening is too big.
- D. air leakage is likely.
- E. None of the choices.

## Airsoft Certification AEG01 Self-assessment V1 ANSWERS

Question 35:

Which of the following is a valid option if the butt stock of your AEG cannot hold a large 9.6V battery pack (choose the single BEST answer):

- A. use an external battery bag.
- B. drill through the butt stock so you can have a separate 1.2V cell hidden at the back.
- C. have a separate 1.2V cell attached to the side of the mechbox.
- D. have a separate 1.2V cell attached to the back of the mechbox.
- E. None of the choices.

## Airsoft Certification AEG01 Self-assessment V1 ANSWERS

Question 36:

Foregrip wobbling is an issue particularly problematic for which of the following AEG models?

- A. TM M4
- B. TM MP5K
- C. ICS MP5
- D. CA AUG
- E. TM G36
- F. CA G36
- G. None of the choices.

## Airsoft Certification AEG01 Self-assessment V1 ANSWERS

Question 37:

Which of the following configurations would better fit a TM MP5K (choose the single BEST answer):

- A. High ROF
- B. High FPS
- C. High FPS and high ROF

## Airsoft Certification AEG01 Self-assessment V1 ANSWERS

Question 38:

Which of the following gun models may be similarly configured?

- A. MP5 and M16
- B. MP5K and G3
- C. MP5K and G3 SAS
- D. FAMAS and P90
- E. None of the choices.

## Airsoft Certification AEG01 Self-assessment V1 ANSWERS

Question 39:

Talking about mechbox electronics, the key factors affecting the quality of the soldering joint should include (choose all that apply):

- A. cleanliness
- B. temperature
- C. adequate solder coverage
- D. None of the choices.

## **Airsoft Certification AEG01 Self-assessment V1 ANSWERS**

Question 40:

You should apply grease on (choose all that apply):

- A. the shaft of the gears
- B. the surface of the shim washers
- C. both sides of the tappet plate
- D. both sides of the piston
- E. None of the choices.

## **Airsoft Certification AEG01 Self-assessment V1 ANSWERS**

For the latest exam status, please visit:

<http://www.airsoftcertification.com/>

*Please email your questions and comments to*

[editor@airsoftpress.com](mailto:editor@airsoftpress.com).