

Airsoft Certification

Self Assessment Exam AEG01, Version 1 Part III

ANSWERS

Proudly presented by the AirsoftPRESS

Airsoft Certification AEG01 V1 – Part III ANSWERS

Question 81:

Refer to the exhibit below:

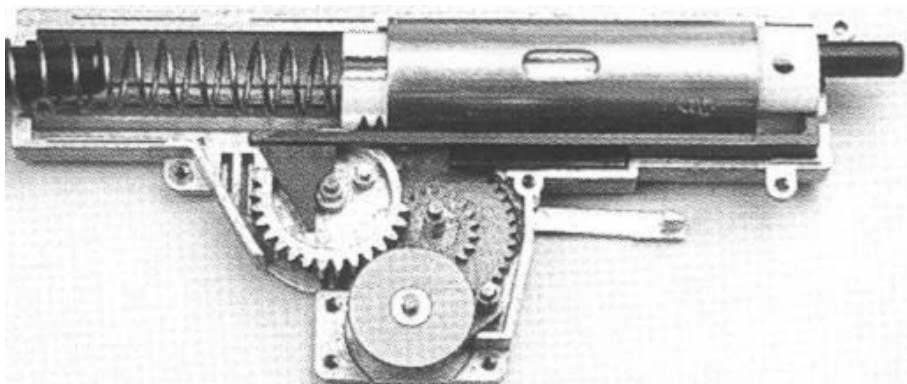

What mechbox version is this?

- A. V6**
- B. V3.5
- C. V4
- D. V3
- E. V5
- F. V5.5
- G. None of the choices.

Airsoft Certification AEG01 V1 – Part III ANSWERS

Question 82:

Refer to the exhibit below:

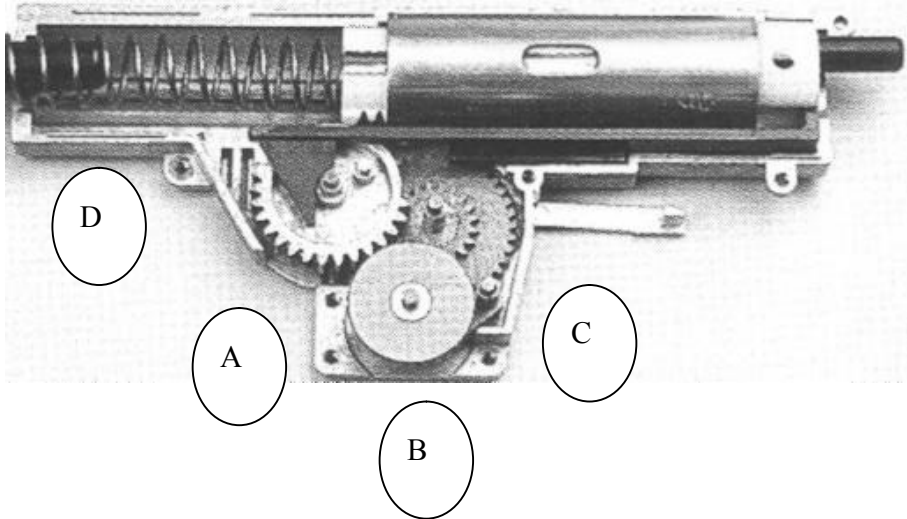

If this mechbox is to be installed in a P90, where would the motor be located?

- A. Location A**
- B. Location B
- C. Location C
- D. Location D
- E. None of the choices.

Airsoft Certification AEG01 V1 – Part III ANSWERS

Question 83:

Refer to the exhibit below:

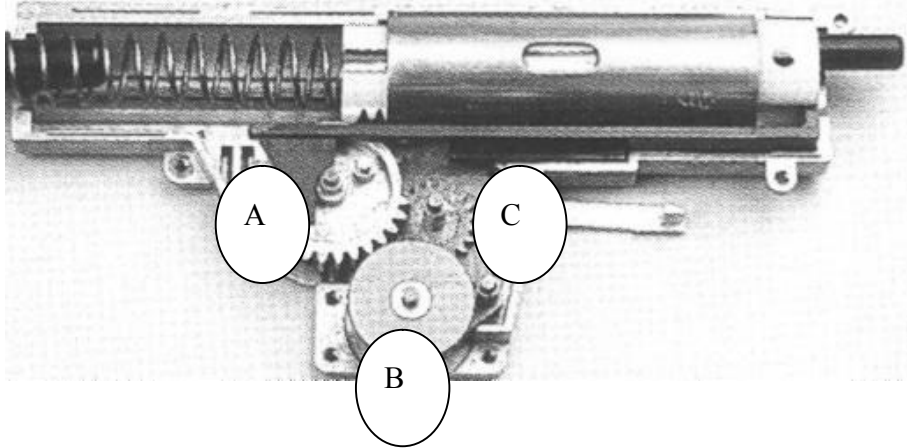

Which gear of this mechbox relies on a special shape bushing rather than a standard round shape bushing?

- A. Gear A
- B. Gear B
- C. Gear C**
- D. None of the choices.

Airsoft Certification AEG01 V1 – Part III ANSWERS

Question 84:

Refer to the exhibit below:

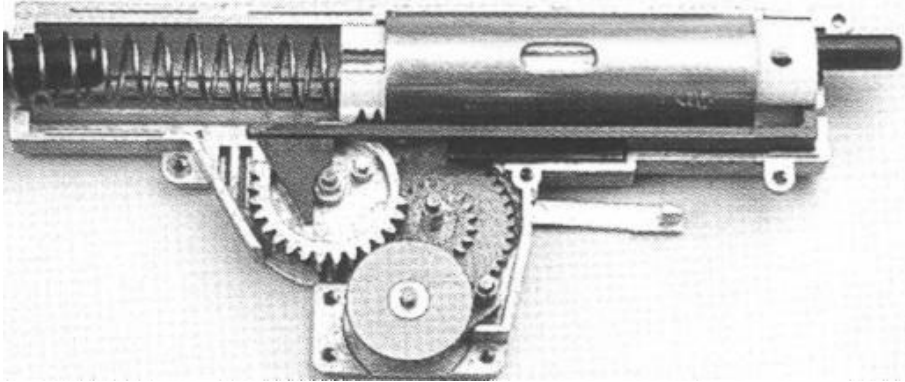

What initial conclusion can you draw from the location of the cylinder opening of the mechbox shown above?

- A. the inner barrel would not be too long**
- B. the inner barrel would be quite long
- C. you want to block this opening for max FPS
- D. you want to block this opening for max ROF
- E. None of the choices.

Airsoft Certification AEG01 V1 – Part III ANSWERS

Question 85:

Refer to the exhibit below:

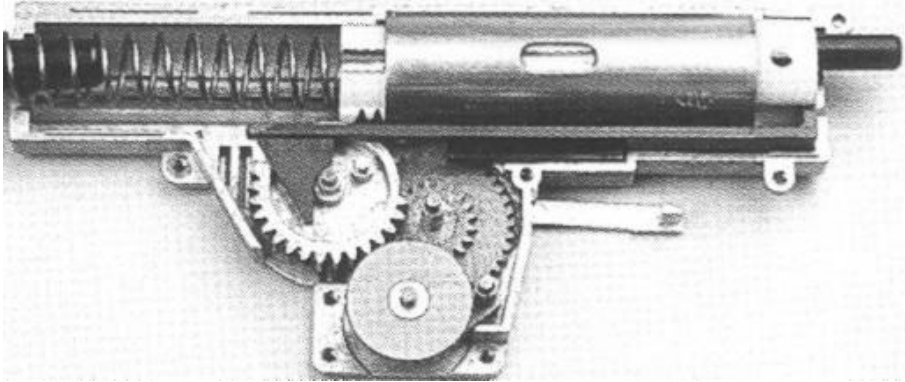

Pay attention to the vertical position of the air nozzle. How come it does not look like it is aligned at the center?

- A. the tappet plate is not correctly installed
- B. the cylinder head is not correctly installed
- C. the piston head is not correctly installed
- D. the mechbox shell has a crack there
- E. None of the choices.**

Airsoft Certification AEG01 V1 – Part III ANSWERS

Question 86:

Refer to the exhibit below:

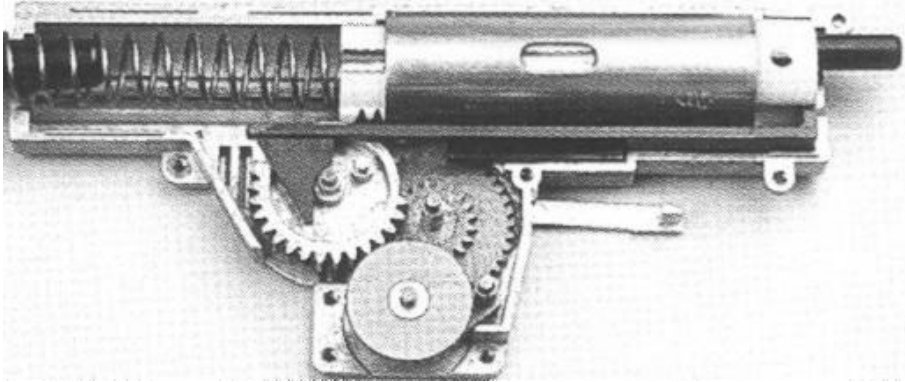

Why would it be impossible for a delayer to be used in the stock mechbox shown above?

- A. the shell is too small
- B. the tappet plate is not compatible
- C. the motor blocks it
- D. the bushing is not compatible
- E. None of the choices.**

Airsoft Certification AEG01 V1 – Part III ANSWERS

Question 87:

Refer to the exhibit below:



The bushings shown are commonly found in which AEG models (choose all that apply):

- A. M4 S System
- B. P90**
- C. G36
- D. SG552
- E. L85
- F. MP5 RAS
- G. None of the choices.

Airsoft Certification AEG01 V1 – Part III ANSWERS

Question 88:

Hopup adjustment of P90 is made:

- A. underneath the stock**
- B. next to the barrel opening
- C. next to the magazine catch
- D. on the rail
- E. None of the choices.

Airsoft Certification AEG01 V1 – Part III ANSWERS

Question 89:

What is the length of the stock inner barrel of a P90?

- A. 247mm.**
- B. 347mm.
- C. 287mm.
- D. 297mm.
- E. 207mm.
- F. None of the choices.

Airsoft Certification AEG01 V1 – Part III ANSWERS

Question 90:

Refer to the exhibit below:



Which AEG models use the kind of battery shown (choose all that apply):

- A. M4 S System
- B. P90**
- C. G36
- D. SG552
- E. L85
- F. MP5 RAS
- G. None of the choices.

Airsoft Certification AEG01 V1 – Part III ANSWERS

Question 91:

Refer to the exhibit below:

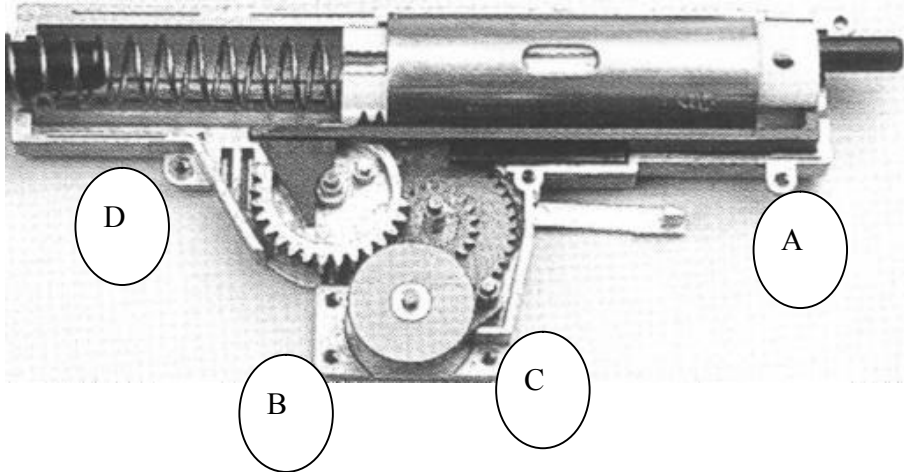

Which screws hold the motor mounting frame firmly in place (choose all that apply):

- A. Screw A
- B. Screw B
- C. Screw C**
- D. Screw D**
- E. None of the choices.

Airsoft Certification AEG01 V1 – Part III ANSWERS

Question 92:

Refer to the exhibit below:

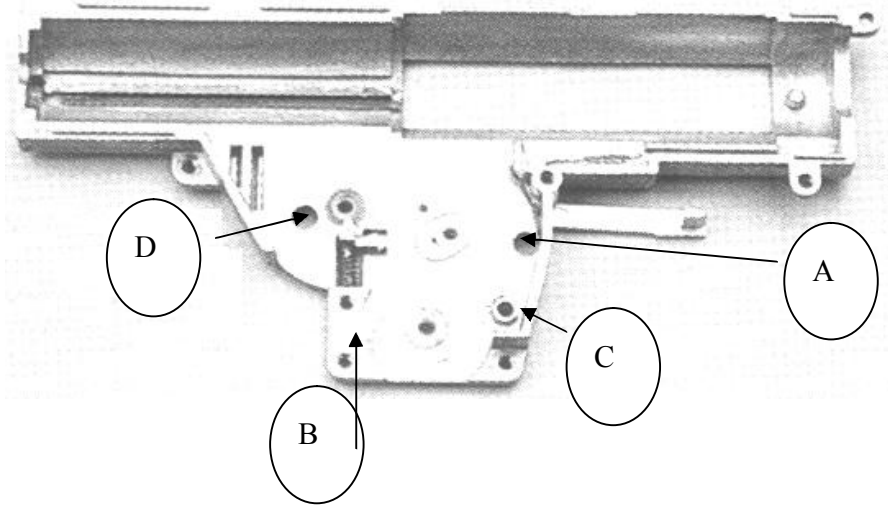

Where would you put in the anti reversal?

- A. location A
- B. location B
- C. location C**
- D. location D
- E. None of the choices.

Airsoft Certification AEG01 V1 – Part III ANSWERS

Question 93:

Which of the following is necessary for the chronographed speed to be accurate (choose the single BEST answer):

- A. proper calibration**
- B. perform test under heavy sun light
- C. perform test indoor
- D. perform test outdoor
- E. perform compute based testing of speed
- F. None of the choices.

Airsoft Certification AEG01 V1 – Part III ANSWERS

Question 94:

Which of the following are the possible ways to “cheat” the velocity testing mechanism (choose all that apply):

- A. use heavy BBs**
- B. use a weak battery**
- C. adjust the hopup to the fullest possible extent**
- D. disable the hopup entirely
- E. None of the choices.

Airsoft Certification AEG01 V1 – Part III ANSWERS

Question 95:

A high ROF setup features fast piston movement as facilitated by which of the following factors (choose all that apply):

- A. a powerful motor.**
- B. an appropriate spring.**
- C. smooth surfaces of the internal moving parts.**
- D. light weight material used by the internal moving parts.**
- E. None of the choices.

Airsoft Certification AEG01 V1 – Part III ANSWERS

Question 96:

The open contact switch used in the AEG mechbox may be replaced by which of the following for enhanced performance and durability?

- A. MOSFET**
- B. close contact switch
- C. capacitor
- D. None of the choices.

Airsoft Certification AEG01 V1 – Part III ANSWERS

Question 97:

To reduce voltage fluctuations you may use which of the following to act as the temporary storage buffer for electric power?

- A. MOSFET
- B. close contact switch
- C. capacitor**
- D. External battery bag
- E. None of the choices.

Airsoft Certification AEG01 V1 – Part III ANSWERS

Question 98:

Rate this comment: The high speed gear set is never intended for very stiff springs.

- A. True**
- B. False
- C. True only for 9.6V configuration.
- D. True only for 8.4V configuration.
- E. True only for 10.8V configuration.
- F. None of the choices.

Airsoft Certification AEG01 V1 – Part III ANSWERS

Question 99:

Which of the following correctly describe the proper design goal of the high speed cylinder set (choose the single BEST answer):

- A. to achieve CONSTANT and CONSISTANT velocity**
- B. to achieve ULTRA HIGH velocity
- C. to achieve zero resistance in piston movement
- D. to achieve zero resistance in nozzle movement
- E. None of the choices.

Airsoft Certification AEG01 V1 – Part III ANSWERS

Question 100:

Which of the following is the most significant bottle neck on ROF (choose the single BEST answer):

- A. the mechbox
- B. the BBs feeding mechanism**
- C. the hopup
- D. the delayer
- E. the sector gear
- F. the motor
- G. the battery
- H. None of the choices.

Airsoft Certification AEG01 V1 – Part III ANSWERS

Question 101:

Refer to the exhibit below:



The kind of battery shown is suitable for which of the following AEGs by default?

- A. MP5K
- B. G36**
- C. P90
- D. AK47
- E. MP7
- F. None of the choices.

Airsoft Certification AEG01 V1 – Part III ANSWERS

Question 102:

Refer to the exhibit below:

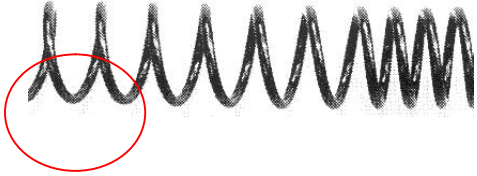

The highlighted area when interfacing with the spring guide may produce what potential problem?

- A. spring spinning may not be smooth**
- B. the spring may break
- C. the spring guide may break
- D. the piston may break
- E. None of the choices.

Airsoft Certification AEG01 V1 – Part III ANSWERS

Question 103:

Which of the following correctly describe the benefits of Telfon Coated finishing (choose all that apply):

- A. It provides a smoother surface**
- B. It can avoid electric shortening that causes sparks.**
- C. It can increase FPS quite significantly.
- D. It can increase accuracy quite significantly.
- E. None of the choices.

Airsoft Certification AEG01 V1 – Part III ANSWERS

Question 104:

When should you consider to use a Bore-Up cylinder (choose all that apply):

- A. you have switched to a very long barrel**
- B. you want very high ROF without sacrificing FPS
- C. you want very high ROF by sacrificing FPS
- D. you prefer high accuracy
- E. None of the choices.

Airsoft Certification AEG01 V1 – Part III ANSWERS

Question 105:

When you install a Bore-Up cylinder you will also HAVE TO install which of the following?

- A. a longer barrel
- B. a high precision inner barrel
- C. a new spring
- D. a new piston head set**
- E. None of the choices.

Airsoft Certification AEG01 V1 – Part III ANSWERS

Question 106:

Refer to the exhibit below:

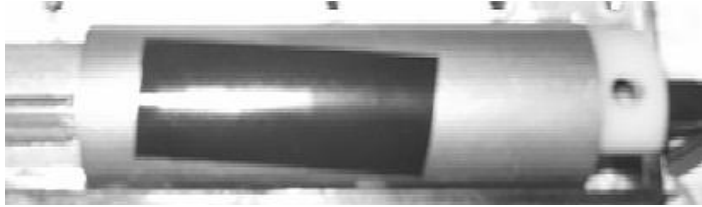

On a MP5 when should this be preferable?

- A. you have switched to a very long barrel**
- B. you want very high ROF without sacrificing FPS
- C. you want very high ROF by sacrificing FPS
- D. you prefer high accuracy
- E. None of the choices.

Airsoft Certification AEG01 V1 – Part III ANSWERS

Question 107:

Refer to the exhibit below:

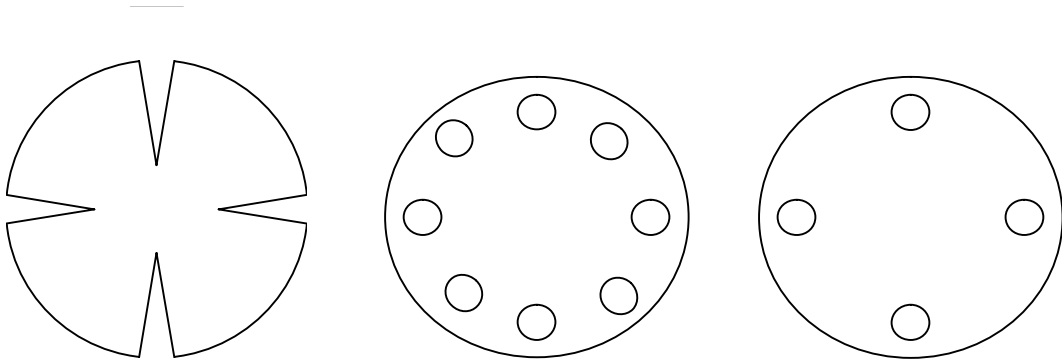

Which of the above shown fails to demonstrate a valid way of DIY piston head enhancement?

- A. the left most one
- B. the middle one
- C. the right most one
- D. None of the choices.**

Airsoft Certification AEG01 V1 – Part III ANSWERS

Question 108:

Which of the following is a valid way of reducing motor heat without forgoing power?

- A. switch to the high torque gear set.**
- B. switch to a smaller cylinder
- C. switch to a shorter piston
- D. use a smaller piston O ring
- E. None of the choices.

Airsoft Certification AEG01 V1 – Part III ANSWERS

Question 109:

Refer to the exhibit below:

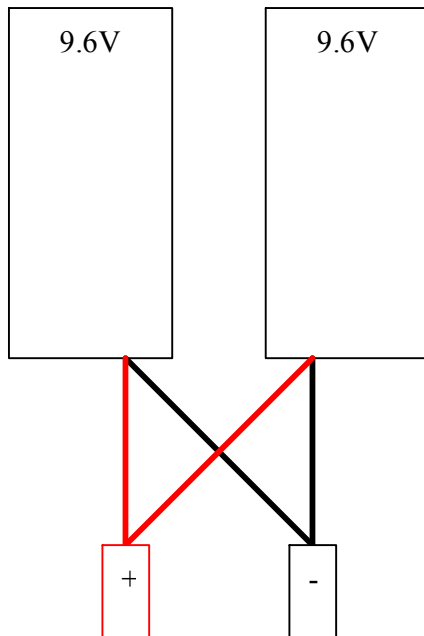

The above shown a battery configuration that is:

- A. doubled capacity**
- B. doubled voltage
- C. a totally wrong configuration
- D. None of the choices.

Airsoft Certification AEG01 V1 – Part III ANSWERS

Question 110:

When would double feeding occur (choose all that apply):

- A. when the feeding mechanism is over lubricated**
- B. when the nozzle is seriously deformed**
- C. when the feeding mechanism is under lubricated
- D. when the battery power is too strong
- E. None of the choices.

Airsoft Certification AEG01 V1 – Part III ANSWERS

Refer to the exhibit below for answering the next 5 questions:

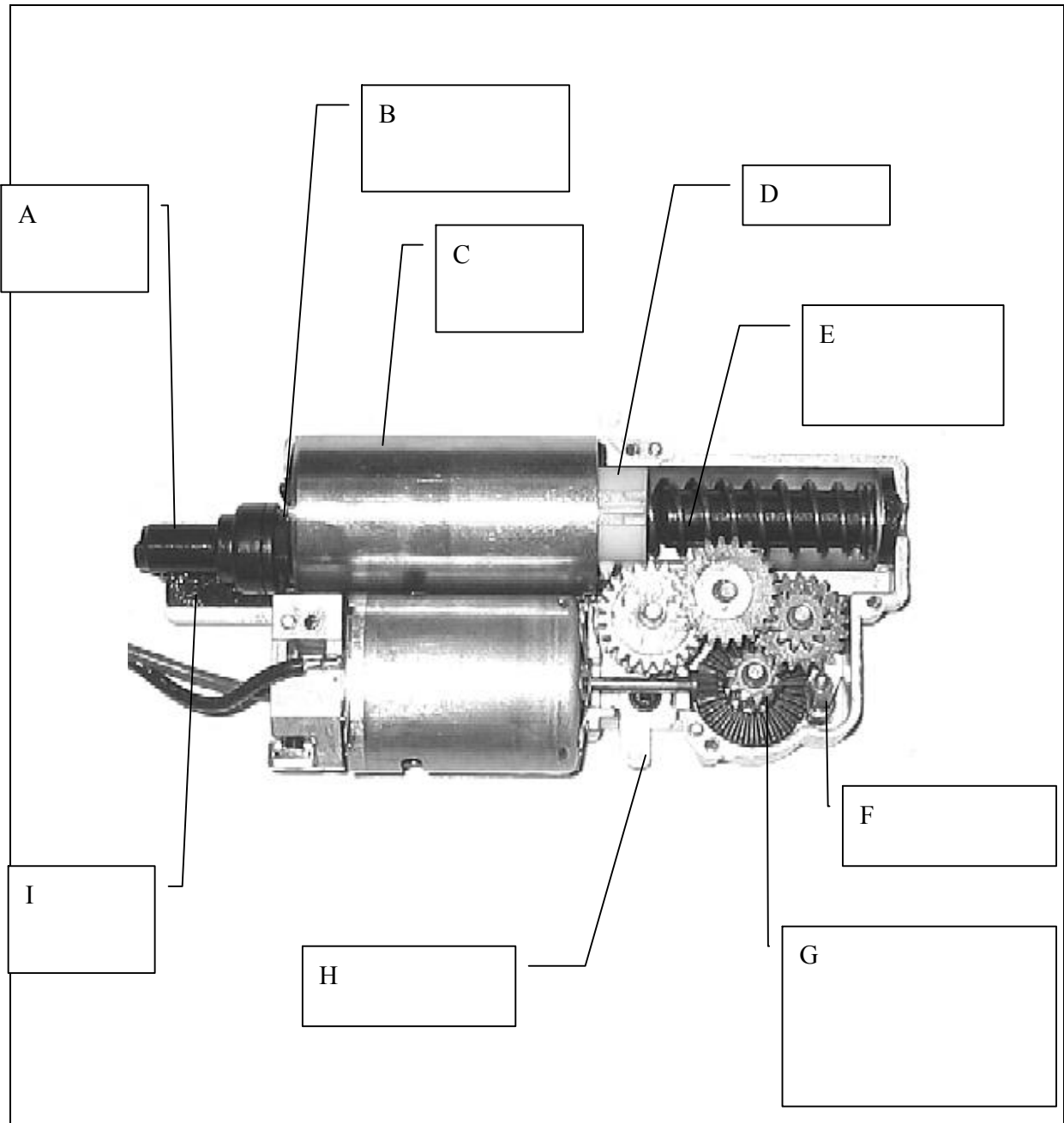

Airsoft Certification AEG01 V1 – Part III ANSWERS

Question 111:

Which of the following is the safety release?

- A. Part C
- B. Part D
- C. Part E
- D. Part F
- E. Part G
- F. Part H**
- G. Part I
- H. None of the choices.

Airsoft Certification AEG01 V1 – Part III ANSWERS

Question 112:

Which of the following is the anti reversal?

- A. Part C
- B. Part D
- C. Part E
- D. Part F**
- E. Part G
- F. Part H
- G. Part I
- H. None of the choices.

Airsoft Certification AEG01 V1 – Part III ANSWERS

Question 113:

Which of the following is the tappet plate?

- A. Part C
- B. Part D
- C. Part E
- D. Part F
- E. Part G
- F. Part H
- G. Part I**
- H. None of the choices.

Airsoft Certification AEG01 V1 – Part III ANSWERS

Question 114:

How many bushings are required for this mechbox to function?

- A. 6
- B. 7
- C. 8**
- D. 9
- E. 10
- F. None of the choices.

Airsoft Certification AEG01 V1 – Part III ANSWERS

Question 115:

How many bevel gears are included in the mechbox?

- A. one**
- B. two
- C. three
- D. None of the choices.

Airsoft Certification AEG01 V1 – Part III ANSWERS

Refer to the exhibit below for answering the next 3 questions:

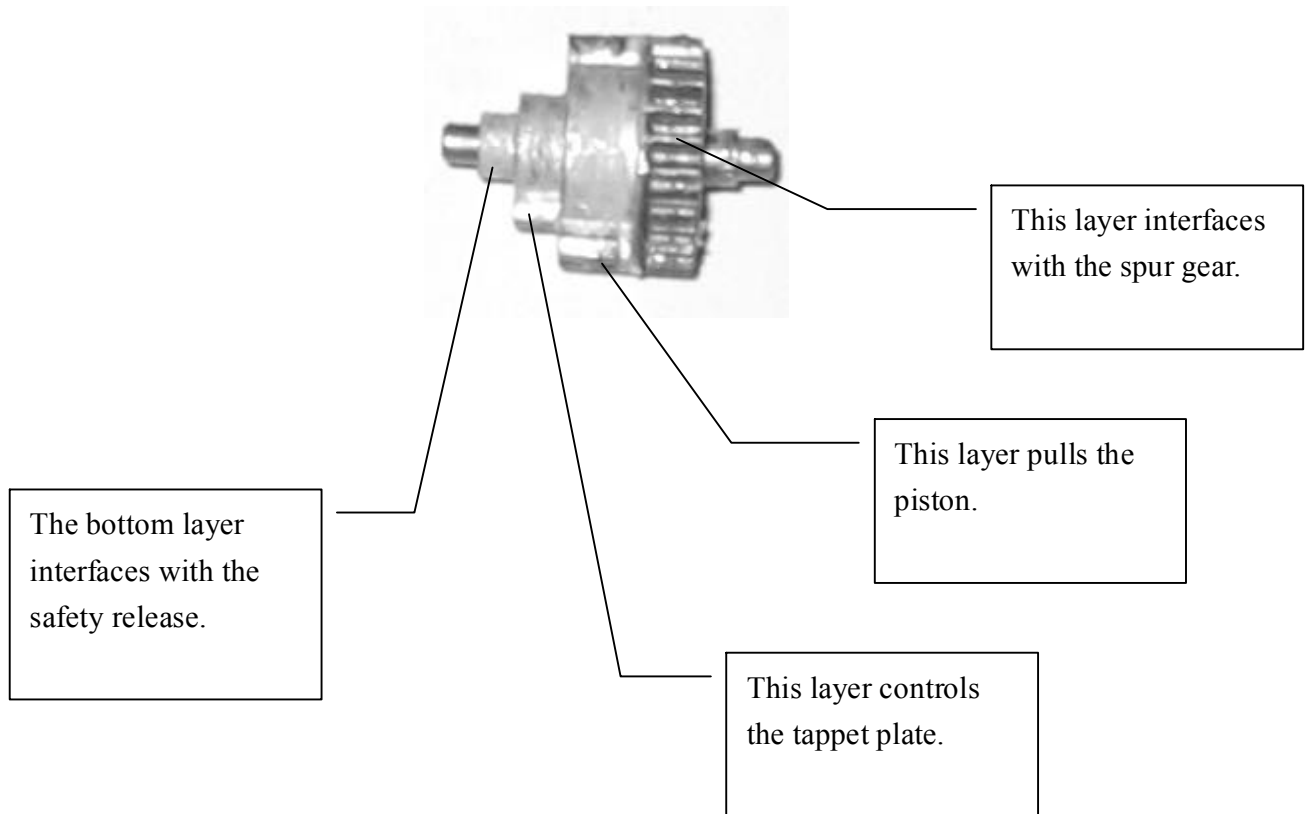

Airsoft Certification AEG01 V1 – Part III ANSWERS

Question 116:

Which layer interfaces with the spur gear?

- A. Layer 1
- B. Layer 2
- C. Layer 3
- D. Layer 4**
- E. None of the choices.

Airsoft Certification AEG01 V1 – Part III ANSWERS

Question 117:

Which layer drives the tappet plate?

- A. Layer 1
- B. Layer 2**
- C. Layer 3
- D. Layer 4
- E. None of the choices.

Airsoft Certification AEG01 V1 – Part III ANSWERS

Question 118:

Which layer interfaces with the safety release?

- A. Layer 1**
- B. Layer 2
- C. Layer 3
- D. Layer 4
- E. None of the choices.